

COBRA FTH190

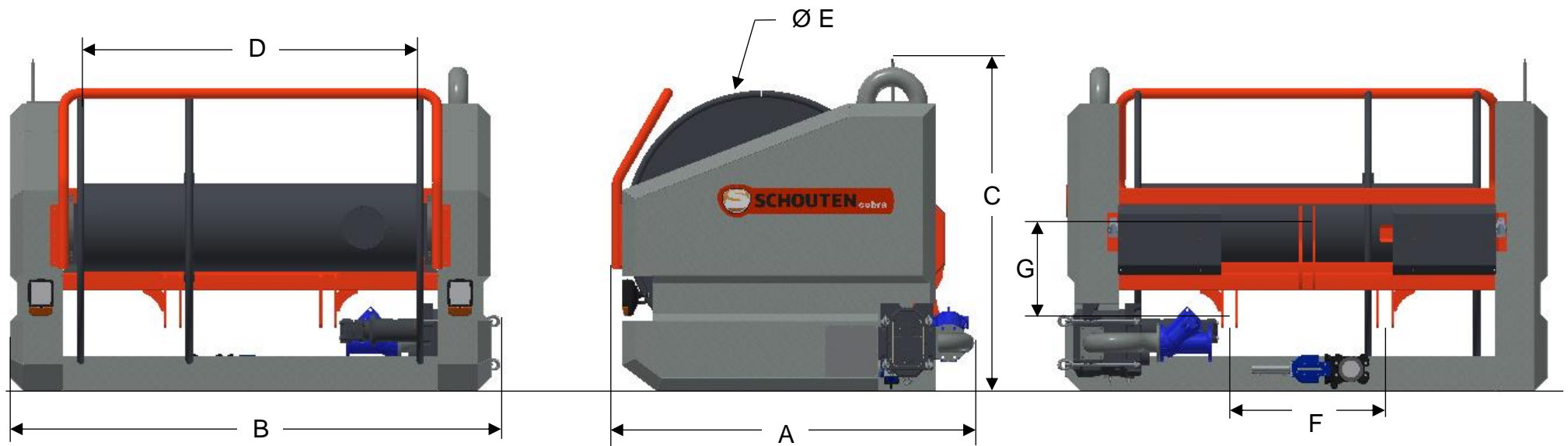

DIMENSIONS

A	LENGTH	2040 MM	E	SPOOL DIAMETER	1500 MM
B	WIDTH	2755 MM	F	HITCH WIDTH	900 MM
C	HEIGHT	1900 MM	G	DISTANCE LIFT PIN – LINK PIN	510 - 590 MM
D	SPOOLWIDTH	1900 MM			

COBRA FTH190

MACHINE INFORMATION

TYPE	FTH190
WEIGHT	1630 KG
HITCH TYPE	3 + 4 PUNKT CAT II
HOSE CAPACITY	1000 MTR - 5"
TANK VOLUME	1.200LTR

TYPE PUMP	ROTARY LOBE PUMP HYDR. DRIVEN
HYDR. POWE REQUIREMENT	100 LTR / 200BAR
DRIVE SPOOLS	HYDR/CHAIN
HYDR. MOTORS/SPOOL	2X 2 OMS200
DRIVE PROTECTION	HYDR. OVER PRESSURE

OPTIONS

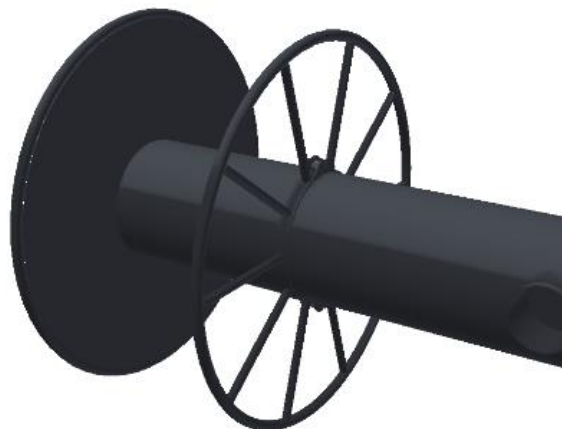

ADJUSTABLE PARTITION